



LAC#3 ABRASIVE GUNS

OPERATING INSTRUCTIONS & REPLACEMENT PARTS

APPLICATIONS:

The LA Abrasive Gun has almost unlimited uses as an etching tool for directory panels, directional signs and name plates; for applying designs to plate glass and glassware, colored and transparent plastics, stone, silver and other metals.

The application of such design on glass and metal, which is now being used for wall surfaces, opens a new field for the decorator equipped with an LA Abrasive Gun.

Stencils for production purposes may be rubber or metal. For a single stenciling operation, stencil paper fastened with rubber cement will prove adequate. Paint and art supply stores carry necessary materials.

INSTRUCTIONS:

1. Abrasive guns can direct a limited amount of abrasive or a strong blast when treating larger surfaces.
 - a. Trigger controls volume of air.
 - b. The nozzle can be adjusted and locked for material control.
2. To operate: Fill polyethylene bottle 3/4 full of selected abrasive. Use Aluminum Oxide, Pumice, Starch or other abrasive that will pass through 30 to 100 mesh screen, depending on etching speed and surface effect desired.
3. To adjust abrasive feed turn LAC-3 Aircap clockwise for less feed, counter clockwise for more feed. Lock position of aircap by tightening D-60 Locknut.
4. Air pressure of 30 to 100 lbs. is used depending upon speed, texture and result desired.
5. With stencil design or mask properly placed on glass, metal or other material to be treated, point LA Abrasive Gun at the surface 2" to 6" from and directly above the stencil. Pull trigger and spread abrasive evenly over the part to be etched or blasted.
 - a. For a sharper line move gun closer to working surface.
 - b. Greater depth can also be obtained by continued coverage of the part to be blasted, or by using sharper abrasive.
6. For faster deeper cutting, or greater production, increase air pressure and abrasive feed.

AIR CONNECTIONS:

Air connections are 1/4" Standard Pipe Thread.

1. Attach air hose to outlet of compressor and blow out airline to remove all foreign particles before connecting to Abrasive Gun.

Paasche Airbrush Company
 4311 North Normandy Avenue
 Chicago, IL 60634-1395
Phone: 773-867-9191 • **Fax:** 773-867-9198
Website: paascheairbrush.com
E-Mail: info@paascheairbrush.com

WARNING: Read instructions for proper care in handling and operation. Always wear a Respirator and Goggles when using the LAC#3 Abrasive Gun. Use in Well Ventilated Area to remove dust. Always read and follow, Cautions and Warnings on materials being sprayed. **Maximum Air Pressure 100 P.S.I.**



LAC#3 is suitable for heavier spray requirements. LAC#3 Abrasive Gun has a steel tip with Carbide insert for longer life.

SBB-4 SANDBLAST BOOTH- (31" Shelf Height Above Floor, 3'6" x 2' Inside Dimensions) Abrasive material is confined within the booth and falls through an expanded metal shelf to the bottom where it is recovered. The tilting glass eye shield permits full view of work area. The booth is constructed of 18 gauge galvanized sheet steel, and can accommodate top or back exhaust. It is available in standard sizes or can be manufactured to fit your special requirements. **SBB-** Booth is furnished without an exhaust system allowing the purchaser to furnish their own "Dust Collection System" if desired. **SBBV-** Booth is furnished with a Ventilating Unit to pull air and abrasive into the booth. Regulator Moisture Condenser Unit and Abrasive Gun are optional equipment, please specify your requirements.



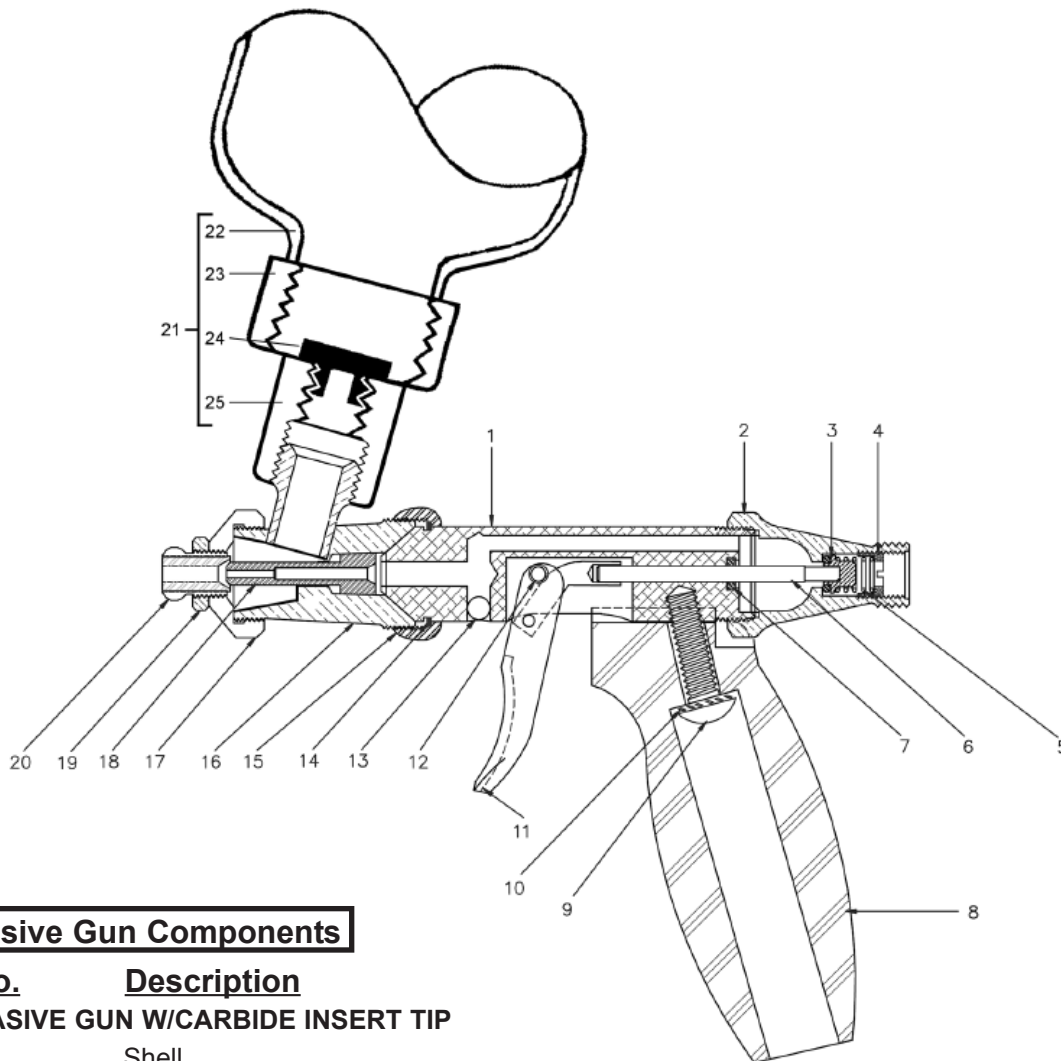

LAC#3 Abrasive Gun Components

No.	Part No.	Description
LAC#3 ABRASIVE GUN W/CARBIDE INSERT TIP		
1	LA-7C	Shell
2	U-49A	Valve Casing
3	U-154P	Air Valve Head
4	U-48	Strainer Nut
5	U-1853	Air Valve Spring
6	L-83A	Piston Rod
7	H-006	"O" Ring
8	L-86	Handle
9	1/4-20x3/4TR	Truss Head Screw
10	1/4ETW	External Tooth Lock Washer
11	L-76A	Trigger & Rod Assembly
12	U-40	Trigger Screw
13	3/16SBB	Ball Bearing Plug
14	U-2153	Retaining Ring
15	U-58	Nut
16	LA-6	Abrasive Body Assembly
17	LA-5	Aircap Nut
18	LA-3N	Nozzle
19	D-60	Lock Nut
20	LAC-3	Carbide Insert Aircap
21	LA-27	Bottle Assembly
22	U-3391	Polyethylene Pint Bottle
23	U-3392	Polyethylene Bottle Cover
24	U-3393	Bushing
25	U-3394	Nut

Accessories for Abrasive Guns - not shown

HL-3/16-6	Air Hose with (2) HLC-3/16-1/4 Cplgs.
HF-1/4	Valve Assembly
U-2061	Fluid Control Screw (Old No.15)
U-1702	Valve Spring (Old No.16)

Abrasive Compounds

ALUMINUM OXIDE - Fast Cutting Compound	
AEX-25	25 Lbs.
AEX-5	5 Lbs.
AEX-6	6 oz.
PUMICE - Medium Cutting Compound	
AE-5	5 Lbs.
AE-6OZ	6 oz.
STARCH - Slow Cutting Compound	
SSO-5	5 Lbs.
SSO-6	6 oz.